

T40RT/T46JRT

TELESCOPIC BOOM LIFT



- Mid-size diesel telescopic boom lifts
- Available with and without a jib boom
- Oscillating axle and 4 wheel drive for excellent rough terrain performance
- Simple to operate and maintain
- Ideal for construction and industrial applications

 **snorkel**
www.snorkellifts.com

TELESCOPIC BOOM LIFT

T40RT/T46JRT

DIMENSIONS	T40RT	T46JRT
Max. working height	14.2m	16.0m
Max. platform height (A)	12.2m	14.0m
Max. working outreach	10.1m	12.2m
Platform size	2.44m x 1.0m	2.44m x 1.0m
Overall width (B)	2.44m	2.44m
Stowed length (C)	7.57m	8.6m
Stowed height (D)	2.4m	2.4m
Wheelbase	2.44m	2.44m
Ground clearance	360mm	360mm

PERFORMANCE		
Platform capacity	272kg	227kg
Max. drive height	12.2m	14.0m
Max. drive speed (stowed)	7.25km/h	7.25km/h
Max. drive speed (elevated)	1.1km/h	1.1km/h
Jib length	n/a	1.8m
Jib arc	n/a	136°
Raise/lower time	64/64 sec	64/64 sec
Gradeability	45%	40%
Inside turning radius	1.37m	1.37m
Outside turning radius	4.57m	4.57m
Tyres	355/55 D625 high grip, poly-filled	
Controls	proportional drive, raise and slew	
Drive system	4 wheel drive with oscillating axle	

POWER		
Power source	Kubota V1505T diesel 44.2Hp	
Auxillary power unit	12V DC	12V DC

WEIGHT		
Gross weight	6,486kg	7,030kg

WORKING ENVELOPE

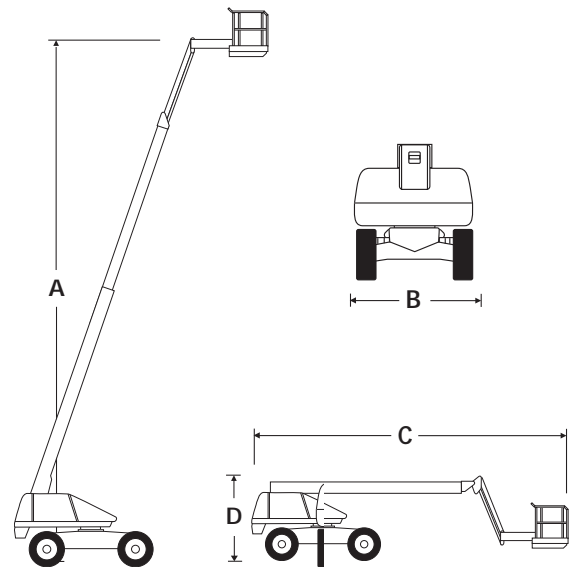
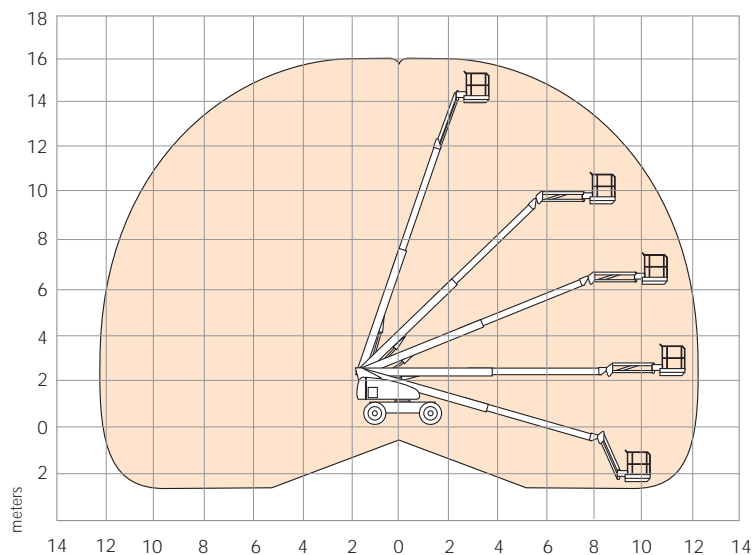

STANDARD FEATURES

- 4 wheel drive
- Oscillating axle
- Swing-out engine tray
- Tilt alarm and cut-out
- Horn
- Power line to platform (no sockets)
- Hour meter
- DC emergency operation
- Three entry cage
- Flashing amber beacon
- CE approved

OPTIONS

- Special paint colours
- 1.82m x 0.99m cage
- Platform work lights
- Hydraulic generator
- Compressed airline to platform
- Steel cowling covers
- Cold weather package
- Extreme cold weather package
- 12k generator package
- 12k generator/welder package

snorkel www.snorkellifts.com

Vigo Centre, Birtley Road,
Washington, Tyne & Wear,
NE38 9DA, U.K.

t: +44 (0) 845 1550 057

e: sales@snorkellifts.com