

TB42/TB47J

TELESCOPIC BOOM LIFT



- Mid-size diesel telescopic boom lifts
- Available with and without a jib boom
- 4 wheel drive for excellent rough terrain performance
- Simple to operate and maintain
- Ideal for construction and industrial applications

 **snorkel**
www.snorkellifts.com

TELESCOPIC BOOM LIFT

TB42/TB47J

DIMENSIONS	TB42	TB47J
Max. working height	48 ft	53 ft
Max. platform height (A)	42 ft	47 ft
Max. horizontal reach	33 ft	39 ft
Platform size	8 ft x 3 ft	8 ft x 3 ft
Overall width (B)	7 ft 11.5 in	7 ft 11.5 in
Stowed length (C)	24 ft	26 ft 9 in
Stowed height (D)	7 ft 9.5 in	7 ft 9.5 in
Wheelbase	8 ft	8 ft
Ground clearance	10 in	10 in

PERFORMANCE		
Platform capacity	500 lbs	500 lbs
Max. drive height	42 ft	47 ft
Max. wind speed	28 mph	28 mph
Max. drive speed (stowed)	3.0 mph	3.0 mph
Max. drive speed (elevated)	0.75 mph	0.75 mph
Jib length	n/a	5 ft
Jib arc	n/a	140°
Platform rotation	150°	150°
Superstructure rotation	360° continuous	360° continuous
Tailswing	49 in	49 in
Gradeability	25%	25%
Inside turning radius	13 ft 6 in	13 ft 6 in
Outside turning radius	19 ft 9 in	19 ft 9 in
Tires	12 in x 16.5 in pneumatic	
Controls	proportional drive, lift and swing	
Drive system	4 wheel drive	4 wheel drive

POWER	
Power source	Kubota 59hp Tier 4i Flex V2403 Turbo Diesel

WEIGHT		
Weight	11,600 lbs	13,500 lbs

WORKING ENVELOPE

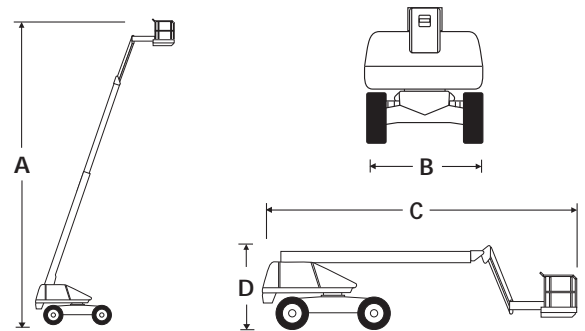
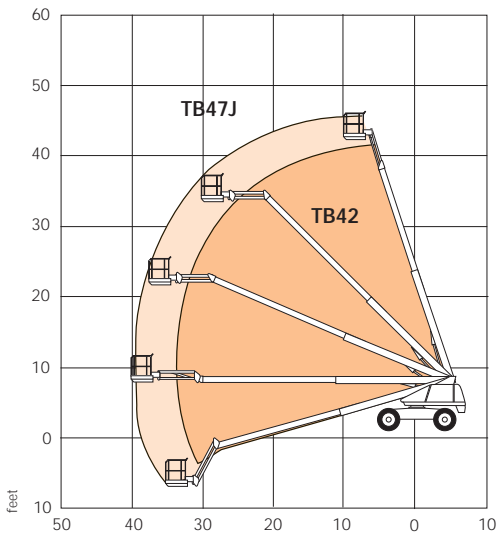

STANDARD FEATURES

- 5 ft, 140° jib (TB47J only)
- 150° hydraulic platform rotation
- 360° continuous turntable rotation
- Proportional drive, lift & swing
- Driveable at full height
- Power line to platform
- Dual lanyard attachment points
- Rheostat control for jib, extend & platform level
- 5° tilt alarm
- Drive motion alarm
- Flashing amber light
- Horn
- Operators manual
- 1 year parts & labor, 5 years structural warranty
- ANSI compliant

OPTIONS

- Special paint colors
- Spark arrest muffler
- Airline to platform
- AC generator 110V/240V 2kW
- Non-marking tires
- Foam filled tires
- Pneumatic high floatation turf tire
- Cold weather package
- Extreme cold weather package
- Extreme environment package
- Light package
- Glazier package
- 12k generator package
- 12k generator/welder package
- CSA compliant

snorkel www.snorkellifts.com

P.O. Box 1160
 St. Joseph, MO 64502-1160, USA
 Tel: 1 (785) 989-3000
 Toll-free: 1 (800) 255-0317
 Fax: 1 (785) 989-3070
 Email: sales.usa@snorkellifts.com